

User's Guide

LPT-6000

9 kHz - 6.2 GHz
Digitally Synthesized RF Spectrum
Analyzer



LP Technologies, Inc.

www.lptech.com

Chapter 1. Product Specifications	5
1-1. Product Specifications	6
 Chapter 2. Preparation for Use	 9
2-1. Initial Inspection	10
2-2. Power Requirements	10
2-3. Fuse Check.....	11
2-4. Power Cable	11
2-5. Environmental Conditions	11
2-6. Turning ON the LPT-6000	12
 Chapter 3. Starting.....	 13
3-1. Front Panel Overview	14
3-2. Rear Panel Overview	17
3-3. Display Overview	18
3-4. Menu and soft key Overview	20
3-5. Measurement Methods	21
3-6. Summary of Measurements.....	22
 Chapter 4. Configuration of a Menu	 24
4-1. Frequency.....	25
4-2. Span.....	25
4-3. Amplitude.....	26
4-4. Marker.....	26

4-5. Peak Search	27
4-6. Marker →	27
4-7. I/O Mode.....	28
4-8. Trace.....	28
4-9. BW/Avg	29
4-10. Trig	29
4-11. Display.....	30
4-12. Sweep.....	31
4-13. Measure	31
4-14. Measure Control	32
4-15. Measure Setup.....	32
4-16. System.....	33
4-17. File.....	34
4-18. File (Save)	35
4-19. File (Load)	36
4-20. File (Delete)	36
4-21. File (Copy)	37
4-22. File (Rename)	37
4-23. File (Create Dir)	38
4-24. Print Setup	38
Chapter 5. Explanation of a Front Board Key	39
5-1. AMPLITUDE.....	40
5-2. BW/Avg	41

5-3. Display	43
5-4. File	44
5-5. FREQUENCY	46
5-6. I/O Mode	47
5-7. Marker	49
5-8. Marker →	51
5-9. Meas Control	53
5-10. Meas Setup	54
5-11. MEASURE	56
5-12. Preset	57
5-13. Print	58
5-14. Print Setup	58
5-15. Return	59
5-16. Peak Search	59
5-17. Single Sweep	60
5-18. SPAN	60
5-19. Sweep	61
5-20. System	61
5-21. Trig	64
5-22. Trace	65
Chapter 6. Options.....	67
6-1. Specifications	68

Chapter 1

Product specifications

In this chapter we will review the LPT-6000 Spectrum Analyzer's specifications

Chapter 1. Product Specifications

1-1. Product Specifications

Frequency

- ▶ Range : 9 kHz to 6.2 GHz
- ▶ Resolution : minimum 1 Hz
- ▶ Span Range : 100 Hz / div to 600 MHz / div
Selection of 1,2,5 steps (automatic), ZERO Span, FULL Span (9 kHz to 6.2 GHz)
- ▶ Frequency Selection : Start, Stop, Center, Span set-up
- ▶ Span Accuracy : $\pm 3\%$ of the Indicated Span Width
- ▶ Readout Accuracy : $\leq \pm (\text{Indicated frequency} \times \text{Reference frequency accuracy} + \text{Span} \times \text{Span accuracy} + 50\% \text{ of RBW})$
- ▶ Phase Noise : ≤ -90 dBc/Hz @10 kHz offset

Amplitude

- ▶ Range : +20 dBm ~ -105 dBm
- ▶ Avg. Noise Level (1 kHz RBW, 10 Hz VBW)
 - ≤ -105 dBm : 150 kHz ~ 1 GHz
 - ≤ -100 dBm : 1 GHz ~ 2.4 GHz, 50 kHz ~ 150 kHz
 - ≤ -95 dBm : 2.4 GHz ~ 6.2 GHz
- ▶ Amplitude Unit : dBm, dBmV, dBuV, V, mV, uV, W, mW, uW
- ▶ Display Scale Linearity
 - $\leq \pm 1.5$ dB / 70 dB (10 dB / div), $\leq \pm 1.5$ dB / 40 dB (5 dB / div)
 - $\leq \pm 0.5$ dB / 8 dB (1 dB / div), $\leq \pm 0.5$ dB / 16 dB (2 dB / div)
- ▶ Frequency Response (0 dB attenuation) : -3.5 dB ~ 1.5 dB (100 kHz ~ 10 MHz)
 ± 1.5 dB (10 MHz ~ 6.2 GHz)
- ▶ Reference Level
 - Range : -90 dBm to +20 dBm
 - Resolution : 0.1 dB step
 - Accuracy : ± 1.5 dB
- ▶ Second Harmonic Distortion : ≤ -60 dBc, -40 dBm input

- ▶ Intermodulation Distortion : ≤ -70 dBc, -40 dBm input
- ▶ Residual Spurious : ≤ -85 dBm (Input terminated, 0 dB attenuation)
- ▶ Other Input Spurious : ≤ -60 dBc, -30 dBm input
- ▶ Resolution Bandwidth
 - Selections : 1 kHz, 3 kHz, 10 kHz, 30 kHz, 100 kHz, 300 kHz, 1 MHz, 3 MHz, 9 kHz, 120 kHz
 - Accuracy : ± 20 %
 - Selectivity : 60 dB / 3 dB ratio $< 15 : 1$
 - 60 dB / 6 dB ratio $< 12 : 1$ (9 kHz, 120 kHz)
 - Switching Error : $\leq \pm 1.0$ dB (1 kHz Reference RBW)
 - Video Bandwidth : 10 Hz to 3 MHz in 1-3-10 step

Sweep

- ▶ Time : 100 ms to 1000 sec, 40 ms to 1000 sec (zero span)
- ▶ Accuracy : $\leq \pm 20$ %
- ▶ Trigger Source : External (rear), Video, Free run, Line
- ▶ Trigger Mode : continuous, single
- ▶ Trigger Level : TTL level

Storage

- ▶ Trace Storage : maximum 900 waveforms
- ▶ Setup Storage : maximum 3,000 states

Screen Display

- ▶ Type : 6.4" color TFT LCD screen
- ▶ Display Resolution : 640 (H) \times 480 (V) active display area
- ▶ Marker Mode : Peak search, Delta marker, Marker to Center, Marker to Reference (8 markers maximum)

Input

- ▶ RF Input Connector : N-type Female, 50 Ω nominal
- ▶ VSWR : 150 kHz to 3.0 GHz, VSWR $< 1.5 : 1$ (with 0 dBm Ref Level) 3.0 GHz~6.2 GHz; VSWR $< 2:1$ (with 0 dBm Ref Level) typical $< 1.5:1$
- ▶ Maximum Input Level : 0 Vdc, +20 dBm

Standard Frequency (10 MHz, Ref.)

- ▶ Temperature Stability : ± 0.5 ppm
- ▶ Aging : ± 0.5 ppm / Year
- ▶ Connector : BNC female
- ▶ Input Level : -5 dBm to +15 dBm
- ▶ Output Level : 10 MHz, +8 dBm nominal

Interface

- ▶ RS-232C (Null modem for remote control)
- ▶ Printer
 - Driver : PCL3 or PCL5, HP, EPSON, Laser-Jet, Desk-Jet etc. supports most printers
 - Connector : Standard 25 pin female D-Sub parallel printer, supports USB
- ▶ USB 2.0 Host
 - Printer Driver : Supports most printers including HP, EPSON, Laser-Jet, Desk-Jet, etc.
 - USB Storage Device : supports 1.1, 2.0, for storing image files, supports GIF format
- ▶ Ethernet (Option)
 - 10-Base-T Ethernet : supports Internet remote control
- ▶ GPIB Interface (Option) : IEEE 488 bus

General Specifications

- ▶ Size : 350 (width) \times 195 (height) \times 375 (length) mm
- ▶ Weight : 10 kg
- ▶ Warming-up Time : 20 minutes for precise measurement
- ▶ Power
 - Supply Electrical Power : 100-240 VAC at 50 / 60Hz
 - Consumption Power : 80 watts maximum (when an option is not built in)
- ▶ Operating Temperature : 0 °C to 40 °C
- ▶ Temperature for Storage : -20 °C to 70 °C
- ▶ RF Emissions, Immunity
 - RF emissions : EN 55011, FCC PART15 Section 15.101
 - RF Immunity : EN 61326
- ▶ Altitude : 75kPa – 106kPa

Chapter 2

Preparation for Use

In this chapter we will review the following:

- Initial inspection
- Power requirements
- Fuse check
- Power cable
- Environmental conditions
- Turning ON the LPT-6000

Chapter 2. Preparation for Use

2-1. Initial Inspection

Please inspect the box contents and make sure all items listed are included. Keep the shipping box and all packing materials until the inspection of the LPT-6000 Spectrum Analyzer is complete.

Table 2-1 (below) shows all accessories offered with the LPT-6000 Spectrum Analyzer. Please contact LP Technologies Customer Support for any damaged parts, missing items, or any other issue that you may need assistance with.

To clean the surface of the unit, please use a wet/dry cloth. Do not clean the inside of the case.

WARNING !

In order to prevent electrical shock, please unplug the power cord from the main power supply on the back of the spectrum analyzer before cleaning.

Accessories	Note:
Operation Manual CD	Included in the package
Power Cable (AC Power Cable 3 Holes)	Included in the package

[Table 2-1] Accessories offered with the LPT-6000 Spectrum Analyzer

2-2. Requirements for Power

The LPT-6000 does not need any additional external devices; use only the power cord provided. For more information, see Table 2-2 below.

[Table 2-2] Requirements for AC Power

Input Voltage	100 - 120 VAC (50 - 60 Hz)
Input Voltage	220 - 240 VAC (50 - 60 Hz)

Power Consumption When Using	Less than 80W
---	---------------

2-3. Fuse Check

A spare fuse should be included with the LPT-6000. The holder is located in the upper part of the power switch on the back of the device. The spare is contained behind the fuse currently in use. If there is no longer a spare fuse in this location, a replacement should be acquired that matches the following properties. (250 VAC, 3.15 A type T 5 × 20 mm).

WARNING !

To reduce the risk of fire, please use only the recommended fuses. Using a fuse with a different power rating may cause serious damage to the spectrum analyzer.

2-4. Power Cable

In accordance with International Safety Standards, the LPT-6000's power cable uses 3 lines including "Ground." When connected to a power outlet, the cable grounds the cabinet of the unit.

WARNING !

Please use a grounded power cable with three lines, or connect the spectrum analyzer to a protective "Ground" line. Operating the unit without following these requirements may put you at risk of an electric shock. It is also important to check the source voltage, because if it exceeds the recommended value, the spectrum analyzer may be permanently damaged or catch fire.

2-5. Environmental Conditions

The LPT-6000 Spectrum Analyzer will operate normally between the temperatures of 0 °C and 40 °C. However, for best performance, it is important to avoid exposing the unit to

conditions involving severe vibration, high moisture, direct sun rays, or areas where the source voltage changes constantly.

WARNING !

To prevent short-circuits due to condensation make sure the spectrum analyzer is fully dry before using it in normal conditions, after storing, or when using it in low temperature environments for long periods of time.

WARNING !

In order to prevent the inner temperature of the unit from rising, there is a cooling fan on the rear panel. Please leave at least 10 cm between the back panel and walls or other nearby devices in order to allow proper air circulation.

2-6. Turning on Power

Please connect the power cord to the back panel of the LPT-6000 Spectrum Analyzer before use, and then press the “On” button on the front panel. Allow the unit to warm up for approximately 20 minutes before operating.

If you intend to use an external signal of 10 MHz as a standard frequency, please use the 10 MHz REF IN input connector on the rear panel.

The signal level should be over -5 dBm.

Chapter 3

Getting started

In this chapter we will review the following:

- Front panel overview
- Rear panel overview
- Display overview
- Menu and soft key overview
- Measurement methods
- Summary of measurements

Chapter 3. Starting

3-1. Front Panel Overview

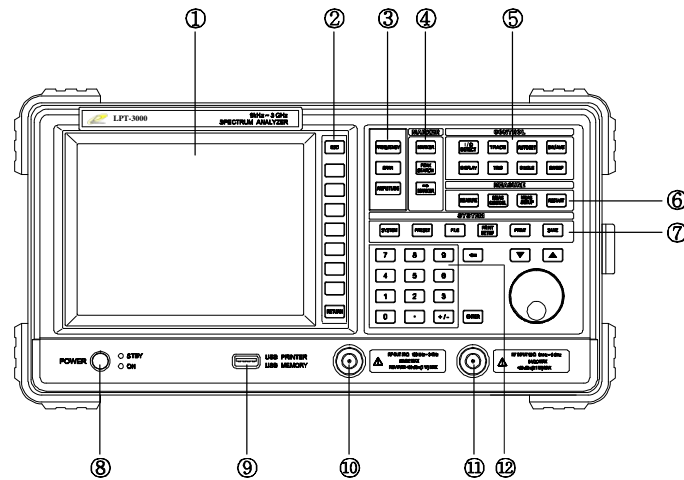

[Figure 3-1] Front panel

1. 6.4" TFT-LCD.

Displays the wave type, parameter set-up, indicated value, and menu key label.

2. Unlabeled soft keys next to the screen.

Allows the user to perform several different functions using the menu displayed on the LCD screen.

3. FREQUENCY, SPAN, and AMPLITUDE keys.

Activates the primary spectrum analyzer functions and access menus of related functions.

The FREQUENCY key allows the user to enter or change the frequency parameter data.

The SPAN key allows the user to enter or change the span parameter data.

The AMPLITUDE key allows the user to enter or change the amplitude parameter data.

4. MARKER function.

Controls markers, reads frequency and amplitude of a trace, and automatically detects the signal with the highest amplitude.

The MARKER key activates the marker function.

The PEAK SEARCH key activates the peak search functions.

MARKER → Sets the marker value as a specific parameter.

5. CONTROL functions.

Allows access to menus that control the spectrum analyzer display and other functions necessary for measurement.

The I/O DETECT key is for setting the input and output of a Ref. 10 MHz signal, and Detect Mode.

The TRACE key is related to the set-up of trace on an LCD screen.

The AUTOSSET key searches for the highest amplitude signal and automatically sets the parameters.

The BW/AVG key is for setting functions including RBW, VBW, and AVG.

The DISPLAY key is for setting the functions of the screen.

The TRIG key is for setting the trigger function.

The SINGLE key is for performing a single sweep.

The SWEEP key is for setting a sweep time and sweep mode.

6. MEASURE functions.

Allows the user to set up, control, and reset the spectrum analyzer's measurement functions and use the built-in compliance masks.

The MEASURE key allows access to measurement tools and compliance masks.

The MEAS CONTROL key is for controlling measurement functions.

The MEAS SETUP key is for setting measurement functions.

The RESTART key is for resetting measurements.

7. The function within the SYSTEM key affects the entire state of the analyzer.

Diverse set-ups and arrangements can be made by using the SYSTEM key.

The PRESET (reset) key will reset the analyzer to its factory default state.

The FILE key menu makes it possible to save the current trace state in the memory of the analyzer or the USB flash memory, or allow loading from them.

The SAVE key immediately performs the currently selected save function.

The PRINT SETUP menu key allows you to select printing options.

The PRINT key immediately sends selected/current data to a connected printer.

8. The power button turns ON/OFF the LPT-6000 Spectrum Analyzer. The Green light indicates the unit is ON and the Red light indicates it is in a STANDBY mode. The main power switch on the back of the unit must be ON to operate the unit. When the unit is ON, press and hold the POWER button for 3 seconds to turn it OFF.
9. USB interface for USB Flash memory stick or USB printer cable.
10. Tracking Generator or CDMA Signal Generator input connector (Optional).
11. RF signal input connection.

Data controlling keys including a step key, a knob, and a number key pad allow the user to change the numeric value of an active function. Turning the knob clockwise increases values while counter-clockwise decreases values. All controlling keys can be used concurrently. For example, the values for the central frequency may be adjusted by using the knob, by punching new values using the key pad, or by using the step keys to increase or decrease the values.

The knob makes it possible to successfully change values for functions such as central frequency, reference level, and a marker location. The scope of the adjustment will be determined by the scale of the scope of measurement. The number key pad is used to input precise values.

3-2. Rear Panel Overview

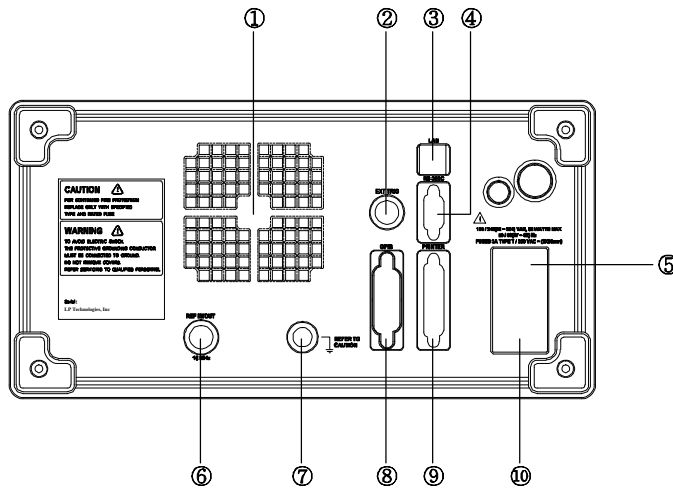

[Figure 3-2] Outline of the Functions of the Rear Panel

1. Ventilation fan is installed to discharge heat generated inside the analyzer.
2. External trigger input connector
3. Ethernet connection interface
4. RS – 232C connection interface
5. AC main power switch (including fuse/spare fuse)
6. Input/Output connector for standard frequency. This port is activated by pressing the I/O DETECT button in the CONTROL section on the front panel of the unit.
7. Ground connection
8. GPIB connector
9. Printer connection
10. AC power switch (including a fuse)

3-3. Display Overview

This is a screen shot of the LPT-6000 display. A description of each item listed is provided below.

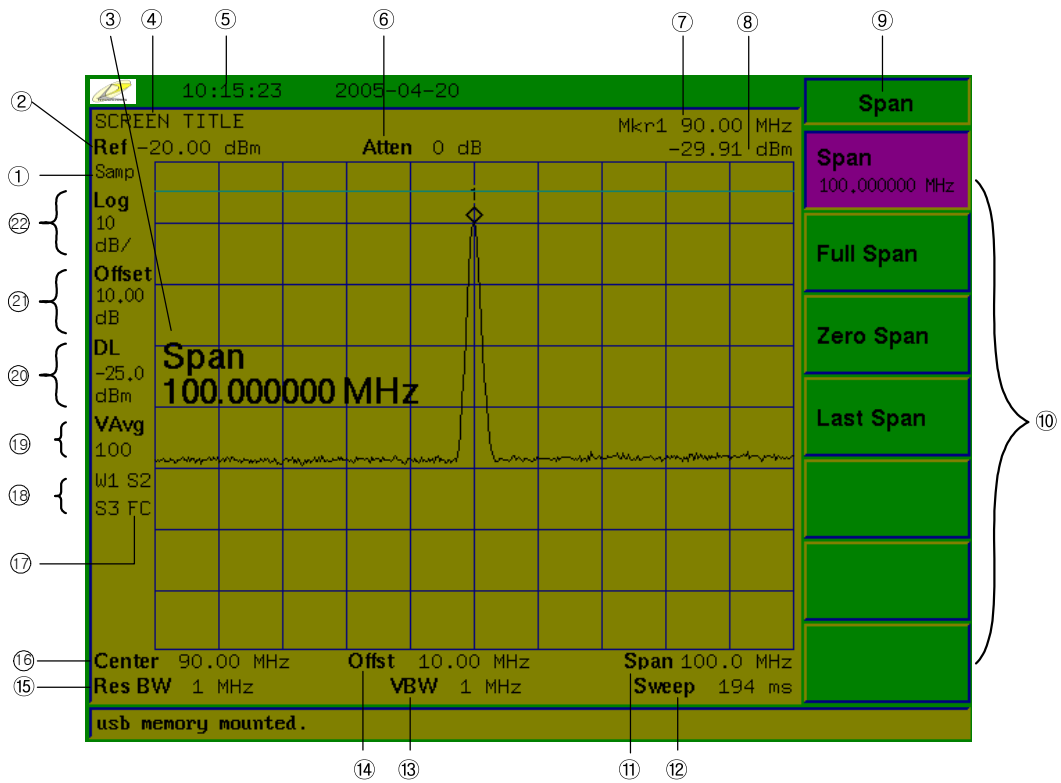

[Figure 3-3] Screenshot

[Table 3-1] Explanation of a Screen

Item	Explanation	Function Key
1	Detect mode	I/O DETECT >> Detect
2	Reference level	AMPLITUDE >> Ref Level
3	Activating function block	Subject to change according to the key selection
4	Screen title	DISPLAY >> Title >> Change Title
5	Time and date	SYSTEM >> Time/Data
6	Attenuation	AMPLITUDE >> Attenuation

Item	Explanation	Function Key
7	Marker frequency	Marker
8	Marker amplitude	Marker
9	Menu title	Subject to change according to the key selection
10	Menu	Subject to change according to the key selection
11	Frequency span or Stop frequency	SPAN or FREQUENCY >> Stop Freq
12	Sweep time	SWEEP >> Sweep Time
13	Video bandwidth	BW/AVG >> Video BW
14	Frequency offset	FREQUENCY >> Freq Offset
15	Resolution bandwidth	BW/AVG >> Res BW
16	Center frequency or starting frequency	FREQUENCY >> Center Freq or FREQUENCY >> Start Freq
17	Trigger / Sweep	TRIG, SWEEP
18	Trace mode	TRACE
19	Video avg.	BW/AVG >> Average
20	Display line	DISPLAY >> Display Line
21	Amplitude offset	AMPLITUDE >> Ref Level Offset
22	Amplitude scale	AMPLITUDE >> Scale/Div

[Table 3-2] Explanation of a Screen on Trace Mode

Screen Code	Explanation
W	Clear Write
M	Max Hold
V	View
S	Blank
m	Min Hold

[Table 3-3] Explanation of a Screen on Trigger Mode

Screen Code	Explanation
F	Free Run
L	Line trigger
V	Video trigger
E	External trigger

[Table 3-4] Explanation of a Screen on Sweep Mode

Screen Code	Explanation
C	Continuous sweep
S	Single sweep

3-4. Menu and Soft key Overview

There are several keys labeled (FREQUENCY, SYSTEM and MARKER...etc) on the front panel of the LPT-6000 Spectrum Analyzer designed to execute specific different functions. Pressing a front panel key accesses a soft key menu that is located along the right side of LCD display.

Soft key menus allow access to a list of related functions to the ones obtained by pressing directly on the front panel keys. Pressing the unlabeled keys, also called soft keys, immediately on the right of the screen will activate the function appearing on the screen next to each key.

The function becomes active when the value of the concerned soft key menu can be changed. Activated functions appear on the LCD screen in the active function block. For example, pressing the FREQUENCY key will display a soft key menu of related functions on the right of the LCD screen. Pressing the soft key corresponding to Start Freq will result in the "Start Freq" being displayed in the active block.

Soft keys with ON and OFF allow the user to turn a function ON or OFF

Soft keys with AUTO and MAN allow the user to auto-couple or manually change values using the number key pad, scroll knob, or the step keys.

3-5. Measurement Methods

A 80MHz standard signal is generated inside the equipment and is used as a test signal.

11. Please turn on the device by pressing the ON button on the front panel and wait until the self test and the alignment process are complete.
12. Press SYSTEM >> Power On/Preset >> Preset Type >> Factory in order, and select Factory Preset.
13. Press **I/O DETECT >> Ref Out (On)** to turn on the 80 MHz standard signal generated inside the LPT-6000 Spectrum Analyzer.
14. Please set the frequency by pressing the **FREQUENCY** key.
The Frequency soft key menu is now activated on the right side of the LCD and the Center Frequency will be displayed on the screen. Using the scroll knob, step key, or number key pad, please set the center frequency to 80 MHz.
15. Please set the span by pressing the **SPAN** key.
The Span soft key menu is now activated on the right side of the LCD and the Span Frequency will be displayed on the screen. Using the scroll knob, step key, or number key pad, please reduce Span Frequency to 20 MHz.
16. Please set the amplitude by pressing the **AMPLITUDE** key
If the peak of the signal does not appear on the screen, you must adjust the amplitude. Press the **AMPLITUDE** key. The REF Level soft key menu will be activated on the right side of the LCD and the Reference Level of 0.0dBm will be displayed on the screen. Use the scroll knob, keypad, or the numeric keypad to adjust the REF level to the desired value until you get a good signal. When you change the reference level values, the amplitude of the highest graticule line will be changed.

The figure 3-4 fully shows the relationship between the Central Frequency and Reference level. The box in the figure shows a display of the analyzer. Changing the

Center Frequency changes the location of horizontal line on the display. Changing the Reference level changes the vertical position of the signal on the display. If you increase the span, the scope of frequency shown horizontally on the display will increase.

[Figure 3-4] The Relationship Between Frequency and Amplitude

17. Please set the marker.

The marker function measures the frequency and amplitude of a signal and places a diamond-shaped marker on the maximum value of the signal. If you intend to activate the marker, please press the Marker key. The Normal button will be highlighted and the marker value will be displayed in the active function block. Please place a marker on the maximum value of a signal by turning the scroll knob. Also, you can automatically place a marker on the peak of the trace by using the PEAK SEARCH key.

The analyzed result of the marker frequency and amplitude will show up on an activated function block, and on the upper right hand corner of the display. If you are determining the amplitude of a signal, please check the analyzed result of the marker.

When other functions are activated, you can find the marker frequency and amplitude on the analyzed result of the marker in the upper right hand corner of the display.

3-6. Summary of Measurement

18. Please press **SYSTEM >> Power On/Preset >> Preset Type >> Factory**. Please press a PRESET key.

19. Turn on the 80 MHz standard signal generated the inside of the spectrum analyzer by pressing **I/O DETECT >> Ref Out (On)**.

20. Set the Center Frequency to **80 MHz**

21. Set the Span Frequency to **500 kHz**

22. The 80 MHz standard signal of the inside of the analyzer is about **-40 dBm**, so using the scroll knob, step keys, or the numeric keypad, adjust the reference level to **-30 dBm**.

23. Set the marker by pressing the MARKER key and moving the marker to the maximum value of the signal, or by pressing PEAK SEARCH.

Please read the amplitude and frequency. It should be indicated as in figure 3-5. The frequency is indicated horizontally, and the amplitude vertically.

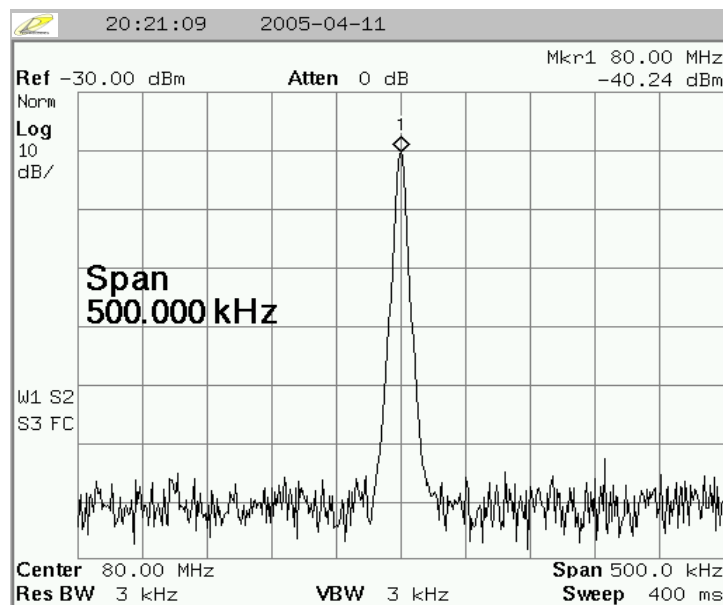

[Figure 3-5] Analyzed Results of Amplitude and Frequency

Menu structure

In this chapter we will review the following:

- Menu Functions
- Menu Structures

Chapter 4. Menu Structure

4-1. Frequency

Frequency

Center Freq
Start Freq
Stop Freq
CF step <u>Auto</u> Man
Freq Offset
Signal Track On <u>Off</u>

4-2. Span

Span

Span
Full Span
Zero Span
Last Span

4-3. Amplitude

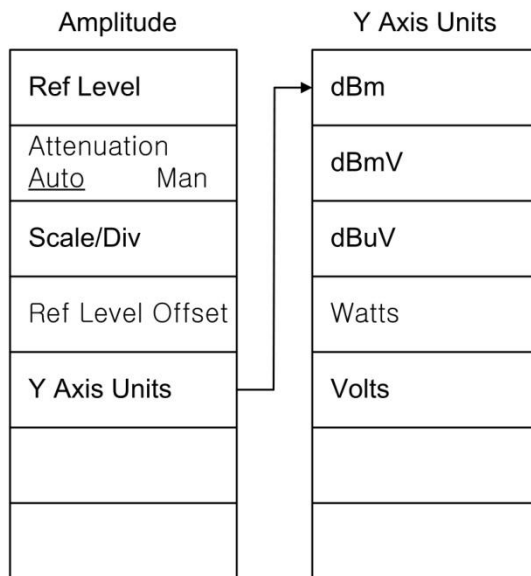

4-4. Marker

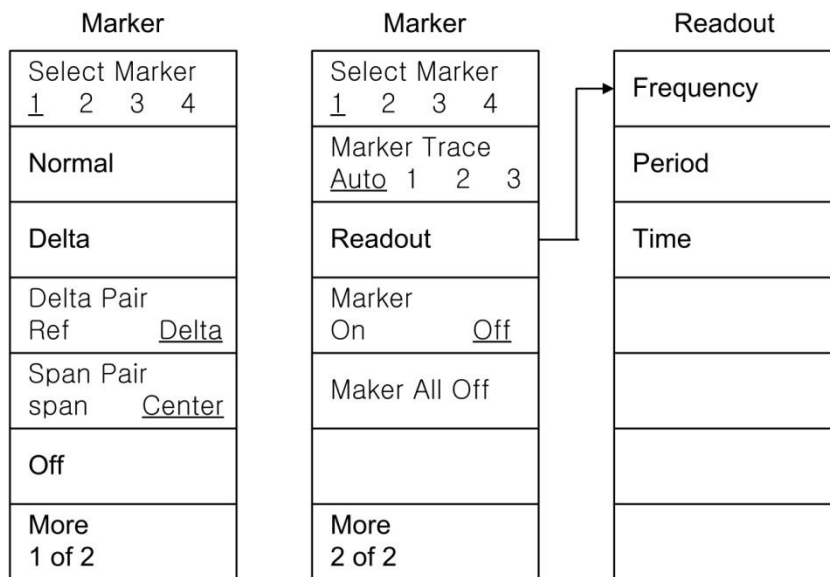

4-5. Peak Search

Peak Search

Next Peak
Next Pk Right
Next Pk Left
Min Search
Pk-Pk Search
Cont Pk On <u>Off</u>
Mkr -> CF

4-6. Marker →

Marker ->

Mkr -> CF
Mkr -> CF Step
Mkr -> Start
Mkr -> Stop
Mkr Delta->Span
Mkr -> Ref Lvl

4-7. I/O DETECT

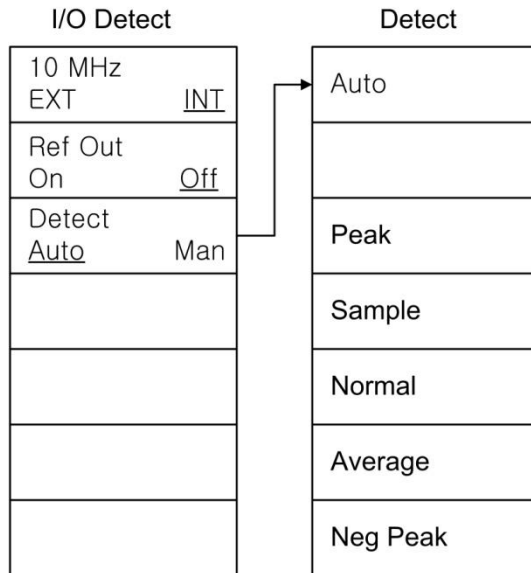

4-8. Trace

Trace		
Trace		
<u>1</u>	2	3
Clear Write		
Max Hold		
Min Hold		
View		
Blank		

4-9. BW/Avg

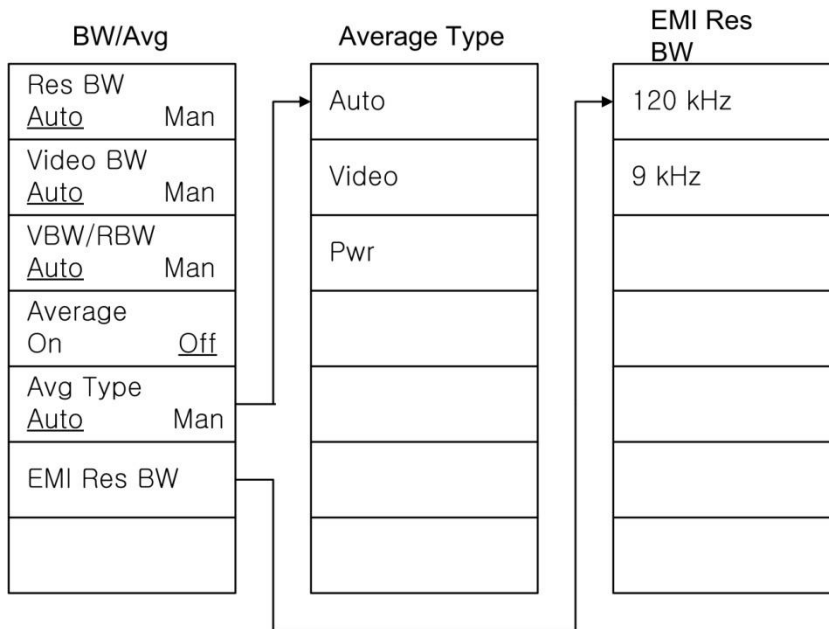

4-10. Trig

Free Run		
Video		
Line		
External		
<u>Pos</u>	Neg	
Trig Delay	On	<u>Off</u>

4-11. Display

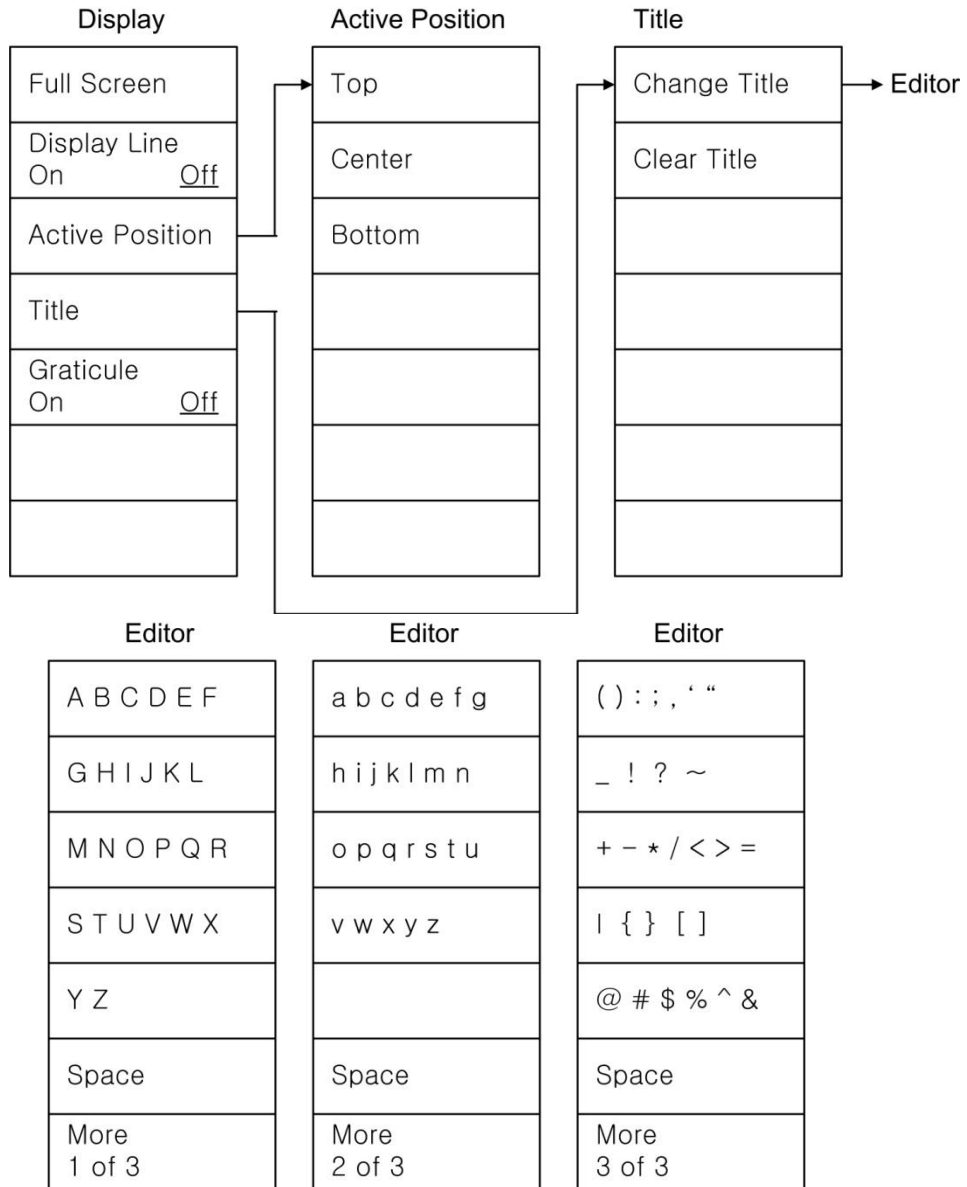

4-12. Sweep

Sweep

Sweep Time <u>Auto</u> Man
Sweep Single <u>Cont</u>

4-13. Measure

Measure

Meas Off
Channel Pwr
Occupied BW
ACP

4-14. Measure Control

Meas Control	
Restart	
Measure Single	<u>Cont</u>
Pause	

4-15. Measure Setup

a. Meas Setup

Avg Number On	<u>Off</u>
Integ BW	
Ch pwr span	

b. Meas Setup

Avg Number On	<u>Off</u>
Occ Bw % Pwr	
OBW Span	
x dB	

c. Meas Setup

Avg Number On	<u>Off</u>
Ch Integ BW	
Offset	

Meas Setup

Offset	<u>A</u>	B	C	D
Offset Freq	<u>On</u>			Off
Offset BW				

- a. Channel Power
- b. Occupied BW
- c. ACP

4-16. System

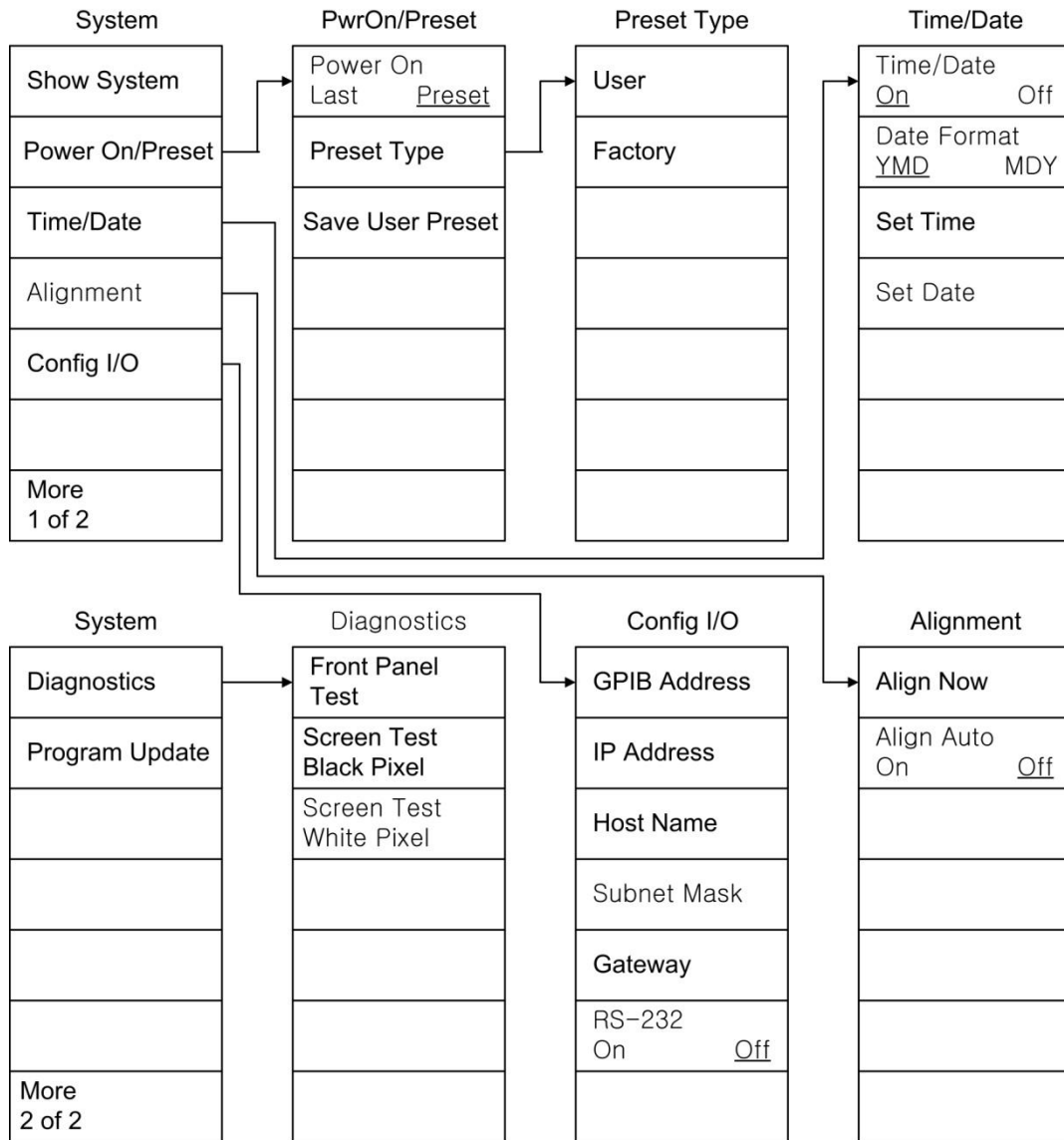

4-17. File

File

Save
Load
Delete
Copy
Rename
Create Dir

4-18. File (Save)

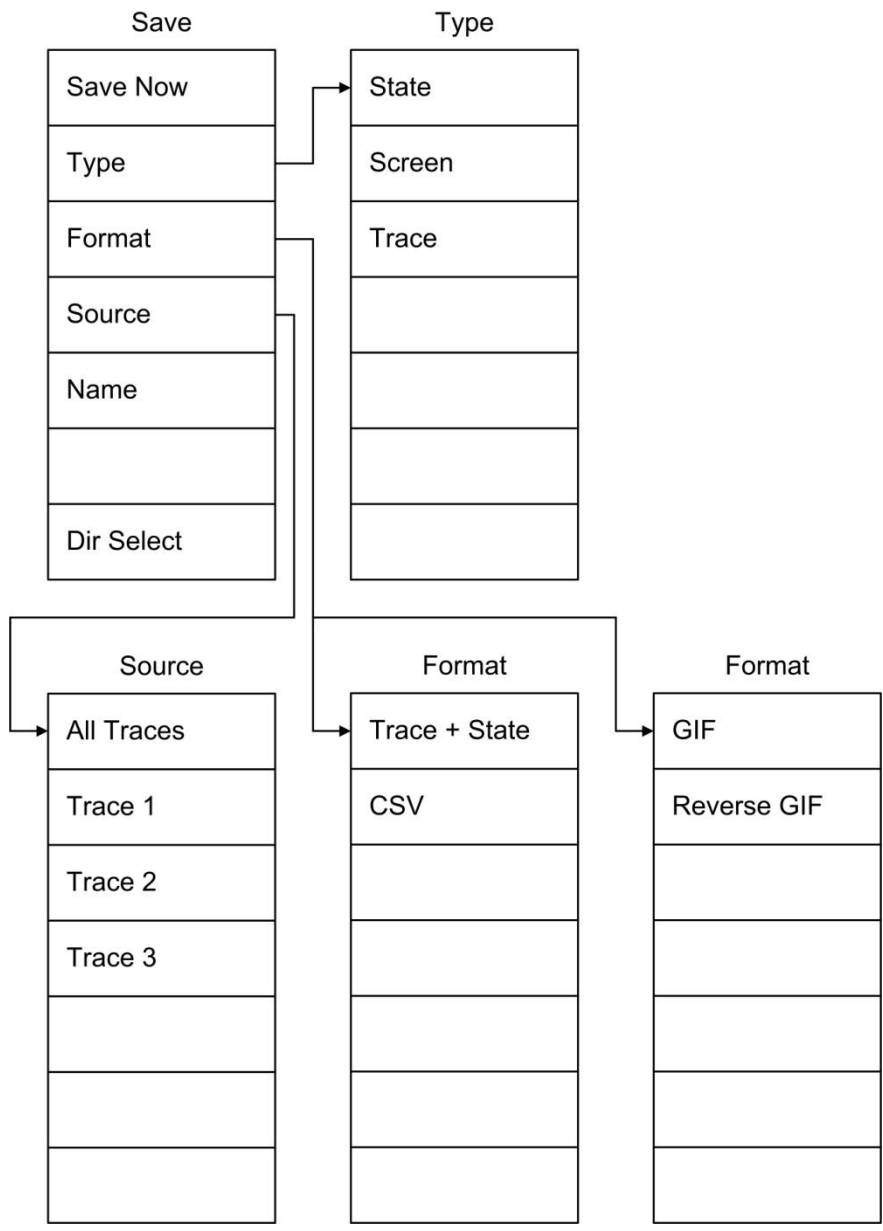

4-19. File (Load)

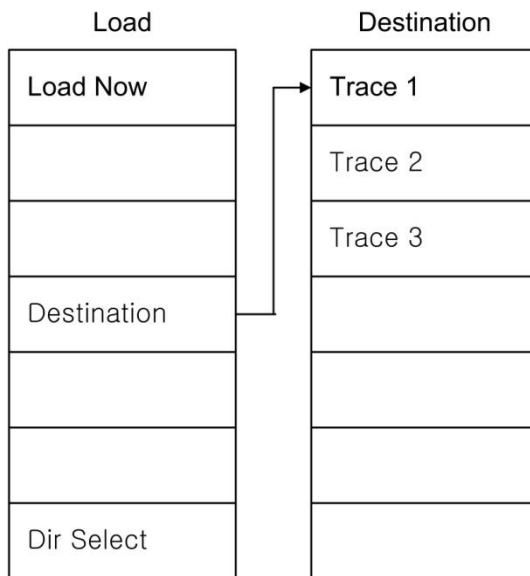

4-20. File (Delete)

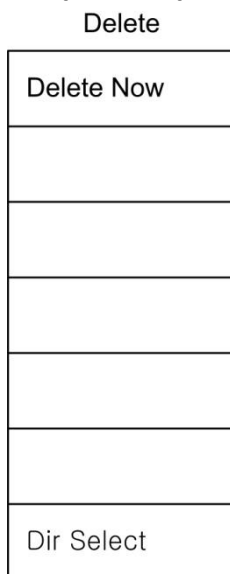

4-21. File (Copy)

Copy

Copy Now
Dir <u>From</u> To
Dir Select

4-22. File (Rename)

Rename

Rename Now
Name → Editor
Dir Select

4-23. File (Create Dir)

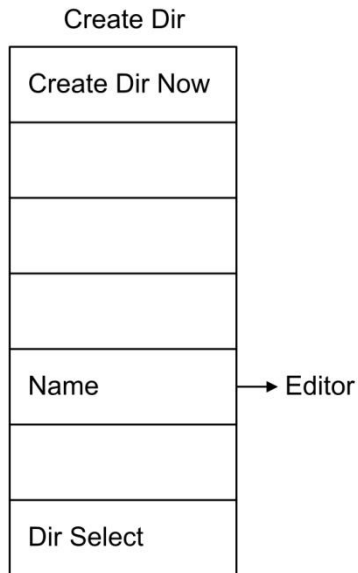

4-24. Print Setup

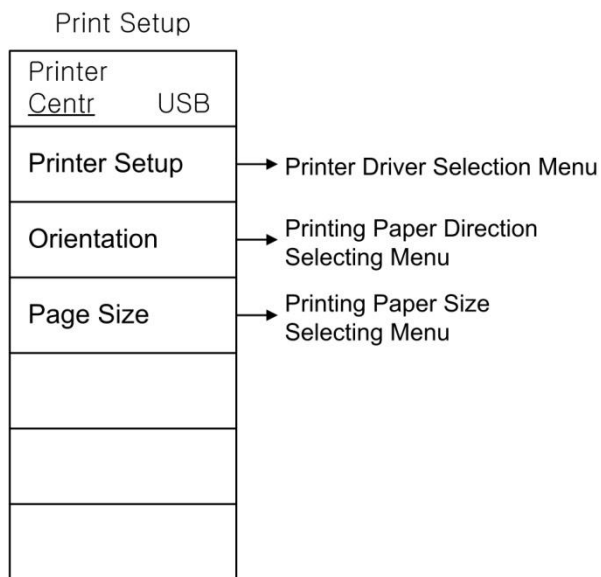

Key descriptions

In this chapter we will review the following:

- Key descriptions
- Menu and soft menu overview

Chapter 5. Explanation of Keys on the Front Panel

5-1. AMPLITUDE

The amplitude key allows the user to activate amplitude related functions such as changing reference level, input attenuation, vertical scale, reference level offset, amplitude units, and pre Amp

■ Ref Level

The Reference Level function is activated when you press the AMPLITUDE key and select the Ref Level soft key. If you change the amplitude, the level indicated on the upper part of the lattice line on the display will indicate the new values. Use the step key, scroll knob, or the number key pad to input or adjust to the desired Ref Level.

AMPLITUDE >> Ref Level

■ Attenuation Auto Man

The input attenuation of the analyzer reduces the power level of the input signal entering the input mixer. You can change the input attenuation value manually by setting the Attenuation menu on MAN and using the step keys, the scroll knob, or the number keypad. You can also set the Attenuation menu on AUTO and it will be automatically set for you.

AMPLITUDE >> Attenuation

■ Scale/Div

This sets the log unit on the vertical lattice sector on the display. The scope of Scale/Div varies between 1 dB and 20 dB per vertical lattice sector, and can be changed in 1dB increments. You can change the input attenuation value by using the step key, scroll knob, or the number keypad.

AMPLITUDE >> Scale/Div

■ Ref Level Offset

This adds the offset value to the currently indicated reference level. The reference level offset value can be changed only by using the numeric keypad. Changing the Reference Level Offset value does not change the trace or the input attenuation value. The reference level offset is used when there is a gain or loss of level between the inputs of a device under test, and the analyzer. Accordingly, a signal level measured by the analyzer can be thought to be the input level of the device for changing external amplitude. After the reference level offset has been changed, the new value will be indicated below the Ref Level Offset soft key on the screen. In order to remove offset, please press Ref Level Offset, 0, dB. Also, if you press Preset, the reference level offset value will be established as 0 dB.

AMPLITUDE >> Ref Level Offset

■ Y Axis Units

This allows the user to change the amplitude unit of measure. You can change the amplitude unit by selecting dBm, dBmV, dB μ V, Volts, or Watts.

AMPLITUDE >> Y Axis Units

5-2. BW/Avg

This activates the resolution bandwidth function, and sets the bandwidth function and the trace average function.

■ Resolution BW Auto Man

The 3 dB resolution bandwidth of the analyzer can be changed from 1 kHz to 3 MHz in a 1. 3. 10. sequence by using the numeric keypad or the step keys. Decreasing the Video Bandwidth increases the Sweep time in order to maintain the amplitude calibration. Also, the resolution bandwidth is connected to the span. When the span decreases, the resolution band will also decrease. If the resolution bandwidth is changed, the video band will be changed in order to keep the ratio of VBW/RBW when in automatic connection mode. When it is not connected, a “#” mark will appear beside the Res BW on a display. Connecting the resolution bandwidth again requires you to press Res BW(Auto).

BW/AVG >> Res BW

■ **Video BW Auto Man**

You can change the analyzer post-detection filter from 10 Hz to 3 MHz in a 1. 3. 10 sequence by using the numeric keypad or the step keys. Decreasing the Video Bandwidth increases the Sweep time in order to maintain the amplitude calibration. When it is not connected, a “#” mark will appear beside VBW on the lower part of the analyzer display. If you intend to connect the resolution bandwidth again, you must press Video BW(Auto), You can change the video bandwidth by using the step keys or the numeric keypad.

BW/AVG >> Video BW

■ **VBW/RBW Auto Man**

This selects the ratio between video bandwidth and resolution bandwidth. You can set the ratio below 1 to reduce the noise in situations where the signal response nears the noise level and is visually marked by it. Use the step keys/numeric keypad to change the ratio in a 1, 3, 10 sequence. You can also set this function on AUTO.

BW/AVG >> VBW/RBW

■ **Average ON/OFF**

This turns ON or OFF the trace average function. When the trace average function is ON, and the detector is set to AUTO mode, it will be changed to the sample mode.

BW/AVG >> Average

■ **EMI Res BW**

This makes it possible to select between the resolution bandwidth of 120 kHz, 9 kHz.

BW/AVG >> EMI Res BW

■ **Avg Type Auto Man**

This displays a menu that makes it possible to select an average type.

▪ **Video**

This function takes the average of the data in the current trace memory, puts it on the trace memory again, and displays it. When the average type video is selected, VAvg will be indicated on the left of the display LCD.

BW/AVG >> Avg Type >> Video

- **Pwr**

This function takes the average by converting data in the current trace memory to a linear power level, then converts it again to a log scale, and then displays it. When the average type is selected, PAvg will be indicated on the left of display LCD.

BW/AVG >> Avg Type >> Pwr

5-3. Display

This is a menu setting, the parts indicated including a title, display line, and the indication of lattice on the analyzer.

- **Full Screen**

This option increases the measuring window to fill the LCD display. Pressing any key will cancel the Full Screen display.

DISPLAY >> Full Screen

- **Display Line On Off**

This activates the display line. The value of the display line is indicated on the activated function block, or on the left of the display. The display line can be moved by using the step keys, the scroll knob, or the numeric key pad. To turn OFF the display line, press Display Line(Off).

DISPLAY >> Display Line

- **Active Position**

This makes it possible to change the location of the active function block on the display.

DISPLAY >> Active Position

- **Title**

This allows the user to name or re-name titles on the display.

- **Change Title**

This enables you to write a title on a title indication line on the upper part of a display. If you press Change Title, the Alpha Editor menu, including usable letters and signs, will appear. The title of the display will be kept until you press Change Title again, or withdraw the trace saved along with the previous title. You can delete the display title by using the delete function.

DISPLAY >> Title >> Change Title

- **Clear Title**

This deletes the title on the upper part of a display. Once deleted, it cannot be restored again.

DISPLAY >> Title >> Clear Title

- **Graticule ON/OFF**

This turns on or off the display.

DISPLAY >> Graticule

5-4. File

This function allows you to load, save, and manage data in the internal memory of the spectrum Analyzer. The file menu key opens a conversation box equivalent to the function selected.

- **Save**

This enables you to save the analyzer state, trace, and screen data in the internal memory.

If you intend to save the file, please perform the following steps:

1. Please select the data type to save by pressing the appropriate menu key.
2. Please select a format you want in a Format conversation box
3. If you intend to change a file name to save, please change the name by using the name menu key.
4. Please press the Save Now menu key after determining a location to save in. When changing a directory to save in, please change the location by using the Dir

Select menu key and the step keys.

- **State**

The state file saves the set-up of the device. You can save the analyzer state in the memory with State.

- **Trace**

Trace can be saved independently or along with the analyzer state. Although CSV type can be read in a form of a spread sheet of the PC, it cannot be drawn to the analyzer. If you save trace 1, 2, or 3, the trace selected can be saved along with the state. If you save the trace as All, the traces are all saved along with State in a .trc single file.

- **Screen**

This enables you to save a screen image on a file, and to select GIF and Reverse GIF file format. The screen image cannot be read with the analyzer.

- **Load**

You can load the analyzer state and trace from the internal memory to the analyzer.

If you intend to load a file, please perform the following steps:

24. Select a file to load by using the step keys. You cannot load a GIF file by the analyzer. As for trace files, please select trace 1, 2, or 3 on Destination.

25. If you are ready to load, please press the Load Now menu key.

- **State**

The state file includes the set-up of the analyzer. If you load the state, a previous state of the analyzer is restored.

- **Trace**

A Trace can be loaded along with the analyzer state when saved. If you load a Trace, it will be in View mode and will default to Trace 1 unless you load all three traces, which will return you to the State in which each Trace was saved.

- **Delete**

This deletes a file in the memory of the analyzer.

- **Copy**

This copies a file to other directories of the internal analyzer or the USB flash memory.

- **Rename**

This allows you to change a file name.

- **Create Dir**

This creates a new directory in the internal memory of the analyzer.

5-5. FREQUENCY

This activates the center frequency set-up function, and displays the menu of the frequency function. Frequency values are show below each specific function in the soft key menu. It is not recommended to enter frequencies larger than the frequency span of the spectrum analyzer.

- **Center Freq**

This sets the Center Frequency using the step keys, scroll knob, and the numeric keypad.

FREQUENCY >> Center Freq

- **Start Freq**

This sets the start frequency. The left and right of the lattice conform to the start and stop frequencies. The Start Frequency can be changed by using the step keys, scroll knob, or the numeric key pad. If you press any number from 0 ~ 9 on the number key pad, a unit menu will appear.

FREQUENCY >> Start Freq

- **Stop Freq**

This sets the Stop Frequency. The left and right of the lattice conform to the start and stop frequencies. The Stop Frequency can be changed by using the step keys,

scroll knob and numeric key pad. If you press any number from 0 ~ 9 on the number key pad, a unit menu will appear.

FREQUENCY >> Stop Freq

■ **CF Step Auto Man**

This allows the operator to change the center frequency step. The center frequency step function is useful for finding out harmonics or side band exceeding the current frequency span of the analyzer. When selecting Auto, the scale of the center frequency step will be established as one lattice (10% of a span). It can be changed by using the step keys, scroll knob, or the number key pad. If you press any number from 0 ~ 9 on the number key pad, a unit menu will appear.

FREQUENCY >> CF Step

■ **Freq Offset**

This enables you to input the frequency offset value. The offset can be inputted only using the numeric keypad. There will be no change on the trace when this function is active. If you intend to remove the offset, please press Freq Offset, 0, Hz. When the frequency offset is entered, the value will show up on the lower part of the display.

Note: This is different from the reference level offset indicated on the left of the display.

FREQUENCY >> Freq Offset

■ **Signal Track ON/OFF**

When this is ON, the peak of the current trace memory is indicated in the center after the sweep is over. Signal Track function is deactivated in a zero span.

FREQUENCY >> Signal Track

5-6. I/O DETECT

■ **10 MHz**

This selects the use of the 10 MHz standard signal of the analyzer. When INT(Internal) is selected, the spectrum analyzer uses the standard signal from the inside of the analyzer, and outputs the 10 MHz standard signal through the port on

the back panel. When EXT(External) is selected, the spectrum analyzer uses the signal coming into the standard frequency input/output port on the back as the 10 MHz standard frequency.

I/O DETECT >> 10 MHz

■ Ref Out (f = 80MHz) On Off

This turns ON or OFF the internal 80 MHz standard signal. When this function is active, RF inputs are de-activated.

I/O DETECT >> Ref Out

■ Detect

It enables you to select among Peak, Sample, Normal, Average, and Neg Peak detection modes.

- **Peak**

When selected, the peak is shown on the upper part of the left of the display. The detection of the peak is mainly used for detecting a signal on the noise level. Peak is used to accurately locate peaks in the frequency. Use the up/down keys to move between peaks.

- **Sample**

When selected, the Samp is shown in the upper left side of the display. The detection of a sample is used for indicating noise or a signal similar to noise. The inspecting signal level on the current display point is saved on a trace memory.

- **Normal**

When selected, the Norm is shown in the upper left side of the display. The detection of normal is the detection mode combining the accurate signal measurement of the peak, and the noise display function of the detection of a sample.

- **Average**

When selected, the Avg is shown on the upper left side of the display. It saves

the average data between the detection of the Peak and the Neg Peak. It is used for reducing VBW or irregular noise without using the trace average function. This function indicates the averaged value with faster sweep speed.

- **Neg Peak**

When selected, the NPK is shown on the upper left side of the display.

The detection of the Neg Peak is used for searching for a similar signal below the noise level. This accurately locates the negative peaks in the frequency. Use the up/down keys to move between negative peaks.

I/O DETECT >> Detect

5-7. Marker

You can turn markers ON or OFF by selecting a marker type and number. The marker is a diamond-shaped symbol showing a point. There can be a maximum of four pairs of markers on the display at the same time. Only one pair can be controlled at a time. The marker controlled is called the “activated” marker. If you press Marker, the Normal menu keys are activated.

- **Select Marker 1 2 3 4**

Selects one of the 4 markers. If a marker is already on, it is activated when selected. When the marker is designated to a different trace while it is already on, the marker will be deactivated on the trace concerned when selected.

MARKER >> Select Marker

- **Normal**

When a marker is not yet indicated, a single frequency marker on the currently selected marker will be activated on the center frequency. When the marker is already indicated, it becomes activated on a selected location. The marker number is indicated on the marker. The indications on the activated function block and the right of the display show the frequency and amplitude of a marker. If you press Normal, the Delta function goes out, and the activated marker moves to the location of the Delta marker.

MARKER >> Normal

■ **Delta**

The second marker is activated on the location of the first marker. (When there is no marker, two markers appear on the center of the display.) The amplitude and frequency of the first marker are fixed. The marker number is indicated on the Delta marker, and the same number is indicated on the standard marker as R. (For instance, 1R) The indications on the activated function block and the right of the display show the difference between the frequency and amplitude of the two markers.

MARKER >> Delta

■ **Delta Pair Ref Delta**

This converts to a mode that allows the two markers to be independently adjusted. When you press Delta Pair, there is a conversion between Reference marker and Delta. The reference marker number is indicated on the marker as R, (for instance, 1R) and Delta marker is indicated as a marker number.

MARKER >> Delta Pair

■ **Span Pair Span Center**

This converts to a mode that allows the two markers to be independently adjusted. If you press Span pair, there is a conversion between the span and the center marker. The reference marker number is indicated on the marker as R, (for instance, 1R) and Delta marker is indicated as a marker number. If you adjust the span, the difference between the two markers will be changed. If you change the center, the center point of the two markers will be changed.

MARKER >> Span Pair

■ **Off**

Turns OFF the Marker function and removes the marker indication on the display.

MARKER >> Off

■ **Marker Trace Auto 1 2 3**

This designates a marker on a trace. If you press Marker Trace Auto 1 2 3, a marker on trace 1 will be activated when there is no marker on. While the marker is currently activated, press Marker Trace Auto 1 2 3 until there is an underline on 1, 2, or 3. The current

activated marker will move to the selected trace. If you select Auto mode, the marker will automatically move to the selected trace.

MARKER >> Marker Trace

■ **Readout**

This changes the activated marker value.

- **Frequency**

This sets the marker value as a frequency. It is a basic value when it is not on zero span.

- **Period**

This sets the marker value as a period. It shows the reverse value of the frequency.

- **Time**

This sets the marker value as a time. It is a basic value when it is on zero span.

MARKER >> Readout

■ **Marker Table On Off**

This shows a marker table on the display. The information includes marker number, trace number, X axis value, and the amplitude.

MARKER >> Marker Table

■ **Marker All Off**

This turns off all markers. Also, it deletes the marker indication.

MARKER >> Marker All Off

5-8. Marker →

■ **Mkr → CF**

This sets the marker frequency as the center frequency. On Delta marker mode, Mkr → CF sets the center frequency as the marker delta value. Mkr → CF cannot be used when it is on zero span.

MARKER → >> Mkr → CF

■ **Mkr → CF Step**

This changes the scale of the center frequency step so that it can match the activated marker value. In order to see the scale of the step, please press FREQUENCY >> CF Step. As for marker delta mode, the scale of the step is established as the difference between a marker and the frequency. Mkr → CF Step cannot be used when it is on zero span.

MARKER → >> Mkr → CF Step

■ **Mkr → Start**

This sets the marker frequency as the start frequency. On delta marker mode, Mkr → Start sets the start frequency as the marker delta value. Mkr → Start cannot be used when it is on zero span.

MARKER → >> Mkr → Start

■ **Mkr → Stop**

This sets the marker frequency as the stop frequency. On delta marker mode, Mkr → Stop sets the stop frequency as the marker delta value. Mkr → Stop cannot be used when it is on zero span.

MARKER → >> Mkr → Stop

■ **Mkr Delta → Span**

This sets the start and stop frequencies as the delta marker. Mkr Delta → Start cannot be used when the marker is off, or is on zero span.

MARKER → >> Mkr Delta → Span

■ **Mkr Delta → CF Step**

This sets the difference between markers as the scale of the center frequency. If you want to see the scale of the step, please press FREQUENCY >> CF Step. Mkr Delta → CF Step cannot be used when the marker is off, or is on zero span.

MARKER → >> Mkr Delta → CF Step

■ **Mkr → Ref Lvl**

This sets the analyzer so that reference level can be the amplitude of a marker. On

delta mode, Mkr → Ref Lvl sets the reference level as the difference of amplitudes between markers.

MARKER → >> Mkr → Ref Lvl

5-9. Meas Control

This enables you to temporarily stop the power measurement function usable on the measure key menu, or resume it. Also, the Meas Control enables you to select continuous sweep or single sweep.

■ Restart

This repeats measurement from the beginning.

MEAS CONTROL >> Restart

■ Measure Cont Single

Measure(Single) indicates the measurement result through a one-time measurement sweep.

Measure(Cont) successively performs measurement, and shows the result for every measurement sweep.

MEAS CONTROL >> Measure

■ Pause

This temporarily stops measurement. If you press Pause, it makes conversion between the temporary pause of measurement and resume.

The key label makes conversion between Pause and Resume.

MEAS CONTROL >> Pause

■ Resume

This resumes the temporarily suspended measurement. The key label makes conversion between Pause and Resume.

MEAS CONTROL >> Resume

5-10. Meas Setup

This indicates the measurement set-up menu. The indicated set-up menu varies based on the selected measurement (ACP, Channel Power, Occupied BW, etc.) on the measure menu.

■ ACP Meas Setup

This sets the adjacent channel power measurement function.

- **Avg Number On Off**

In order to designate the average measurement number, please press Avg Number (On). When each sweep is over, the average value will appear.

MEAS SETUP >> Avg Number

- **Ch Integ BW**

This designates the scope used in calculating the power on the center channel.

MEAS SETUP >> Ch Integ BW

- **Offset BW**

This designates the scope used in calculating the adjacent channel power.

MEAS SETUP >> Offset >> Offset BW

- **Offset Freq**

This designates the difference between the center frequency of the center channel, and the center frequency of the adjacent channel.

MEAS SETUP >> Offset >> Offset Freq

■ Channel Power Meas Setup

This sets the channel power measurement function.

- **Avg Number On Off**

In order to designate the average number, please press Avg Number (On). The average value will appear when each sweep is over. Avg Number (Off) inactivates the average measurement.

MEAS SETUP >> Avg Number

- **Integ BW**

This sets the scope for making calculations of channel power.

MEAS SETUP >> Integ BW

- **Chan pwr span**

This sets the span of the analyzer for channel power measurement.

- **Occupied BW Meas Setup**

This sets the occupied bandwidth measurement function.

- **Avg Number On Off**

In order to designate the average number, please press Avg Number (On). The average value will appear when each sweep is over. Avg Number (Off) inactivates the average measurement.

MEAS SETUP >> Avg Number

- **OBW span**

This sets the span of the analyzer for the occupied bandwidth measurement.

MEAS SETUP >> OBW Span

- **Occ BW % Pwr**

This changes the ratio of signal power used for determining the occupied bandwidth.

MEAS SETUP >> Occ BW % Pwr

5-11. MEASURE

This performs diverse measurement functions including the Adjacent Channel Power, Channel Power, and Occupied Bandwidth

■ Meas Off

This turns off the measurement function.

MEASURE >> Meas Off

■ ACP

This calculates the power in the center and adjacent channel of a signal. A marker point can be established as a measurement set-up menu while ACP is selected.

If you press Meas Setup while ACP is selected, you can set the adjacent channel power measurement parameter. If you press Meas Control when ACP is selected, the measurement can be temporarily suspended or resumed or makes conversion between continuous or single modes.

MEASURE >> ACP

■ Channel Power

This calculates power and power spectrum density on a channel bandwidth designated by a user. A marker on the display indicates the end of the channel bandwidth. The marker selects Channel Power, and can be established as a Meas Setup menu. It operates on single or continuous sweep mode.

If you press Meas Set-up after selecting Channel Power, you can set the channel power measurement parameter. If you press Meas Control after selecting Channel Power, you can temporarily suspend or resume measurement or make conversion between continuous or single sweep modes.

MEASURE >> Channel Pwr

■ Occupied BW

The basic value of measurement is 99% of occupied bandwidth power. The measurement operates on single or continuous sweep mode.

If you press Meas Set-up after selecting Occupied BW, you can set the occupied bandwidth power measurement parameter. If you press Meas Control after selecting Occupied BW, you can temporarily suspend or resume measurement or make conversion between continuous or single sweep modes.

MEASURE >> Occupied BW

5-12. Preset (Reset)

The PRESET key initializes the analyzer back to the factory default state. As for the set-up of the preset state, please refer to the following table of conditions. If you wish to select Preset (Factory), press SYSTEM >> Power On/Preset >> Preset Type (Factory).

[Table 5-1] Factory Preset Conditions

Amplitude Unit	dBm
Indication and Lattice Display	On
Attenuation	30 dB
Center Frequency	3.1 GHz
Start Frequency	0 Hz
Stop Frequency	6.2 GHz
CF Step	10% of a span
Detect	Normal
Display Line	-25 dBm, display turns off.
Frequency Offset	0 Hz
Log Scale	10 dB per sector
Reference Level	0 dBm
Reference Level Offset	0 dB
Marker	Off
Resolution Bandwidth	3 MHz (Auto)
Video Bandwidth	3 MHz (Auto)
VBW/RBW Ratio	1.000
Video Avg.	Off
Span	6.2 GHz

Sweep	Continuous
Title	Clear
Trace 1	Clear-Write
Trace 2	Blank
Trace 3	Blank
Trigger	Free Run

5-13. Print

Please press the Print key if you want to print a copy of the screen using a recommended printer. The screen will remain temporarily suspended until the data transmission is completed. (No more sweeps are initiated).

5-14. Print Setup

This defines a printer, and selects a printer option.

■ **Printer**

Determine whether to output printed data via a Centronics printer port or USB printer port.

PRINT SETUP >> Printer

■ **Printer Setup**

Select a printer driver.

PRINT SETUP >> Printer Setup

■ **Orientation**

Select between Portrait or Landscape print.

PRINT SETUP >> Orientation

■ **Page Size**

Select paper size.

PRINT SETUP >> PageSize

5-15. Return

This returns you to the previous menu.

5-16. Peak Search

This automatically places a marker on the highest amplitude signal of the trace and displays the marker's amplitude and frequency. If there is no peak, the marker will not move. If there is no marker indicated, marker 1 will appear.

■ Next Peak

This detects the second highest peak next to the current marker label, and moves it to that place.

PEAK SEARCH >> Next Peak

■ Next PK Right

This moves the marker to the next highest peak to the right of the current marker. In order to be recognized as a signal peak, a peak must attain at least the value of Excursion (default 6 dB). If there is no peak on the right, the marker will not move.

PEAK SEARCH >> Next PK Right

■ Next PK Left

This moves the marker to the next highest peak to the left of the current marker. In order to be recognized as a signal peak, a peak must attain at least the value of Excursion (default 6 dB). If there is no peak on the left, the marker will not move.

PEAK SEARCH >> Next PK Left

■ Min Search

This moves a marker on the current trace to the minimal level.

PEAK SEARCH >> Min Search

■ PK-PK Search

This finds out and indicates the difference in frequencies between the highest tracer point and the lowest tracer point (or when the span is 0), and the amplitude.

PEAK SEARCH >> PK-PK Search

- **Continuous Pk On Off**

When this is ON, the marker is located on the highest level of trace, and when the sweep is over, it successively detects the highest level, and locates the marker.

PEAK SEARCH >> Continuous Pk

- **Mkr → CF**

This sets the center frequency of the analyzer as the marker frequency. On delta mode, Mkr → CF sets the center frequency as the marker delta value. Mkr → CF cannot be used when it is on zero span.

PEAK SEARCH >> Mkr → CF

5-17. Single Sweep

When the analyzer is in continuous sweep mode, this converts to a single sweep. When the analyzer is already on single sweep mode, it performs a new sweep once if the trigger meets the conditions.

- **SINGLE**

SWEEP >> Sweep

5-18. SPAN

This activates the span function, and makes it possible to change the span.

- **Full Span**

This sets the span as the entire frequency scope of the analyzer.

SPAN >> Full Span

- **Zero Span**

This changes the frequency span to 0.

SPAN >> Zero Span

■ **Last Span**

This changes the frequency span of the analyzer to the previous span.

SPAN >> Last Span

5-19. Sweep

This Accesses the sweep time menu and accesses the sweep-time soft key functions.

■ **Sweep Time Auto Man**

This sets the length of time in which the spectrum analyzer sweeps the frequency span. If the sweep time is reduced, the sweep speed increases. The sweep time can be changed by using the step keys, scroll knob, or the numeric key pad.

SWEEP >> Sweep Time

■ **Sweep Cont Single**

This switches between continuous sweep mode and single sweep mode. If you press Sweep (Single), the analyzer will run a single sweep; when Sweep (Cont) is selected, one sweep will follow the other according to the PRESET SPECTRUM.

SWEEP >> Sweep

5-20. System

The System menu appears.

■ **Power On Preset**

If you press the Power On Preset button, the following menu will appear.

▪ **Power On Last Preset**

This determines the state of the analyzer when you turn it on. This function allows the analyzer to revert to the most recent state it was in when it was powered down. You must use the Power on/Presets menu key to change the

preset state that is loaded upon powering on the analyzer.

- **Preset Type Factory User**

If you press Preset (Factory), the analyzer resets to factory defaults upon startup. If you press Preset (User), you can setup the analyzer as saved by the Save User Preset key. (Please refer to Preset in this chapter.)

Save User Preset

When you press Save User Preset, the current state of the analyzer is saved on the User Preset register.

- **Time/Date**

Provides a menu allowing you to change time and date.

- **Time/Date**

This turns on and off the time and date.

SYSTEM >> Time/Date >> Time/Date

- **Date Format**

This changes the display type of a date from MM-DD-YY to DD-MM-YY.

SYSTEM >> Time/Date >> Date Format

- **Set Time**

This sets the time. Please enter the time in a 24 hrs HHMMSS format by using the numeric keypad, then press Enter. The effective time values (HH) are 00 ~ 23. The effective MM and SS values are 00 ~ 59.

SYSTEM >> Time/Date >> Set Time

- **Set Date**

This allows you to set the date. Please enter a date in YYYYMMDD format by using the numeric keypad, then press Enter. The effective YYYYs are from 2000 to 2037. The effective MM value is 01 ~ 12, and the DD is 01 ~ 31. Use the following keys.

SYSTEM >> Time/Date >> Set Date

■ Alignments

This enables you to accurately acquire frequency and level by arranging the internal circuit of the analyzer.

▪ Align Now

This immediately starts the arrangement of the system.

SYSTEM >> Align Now

▪ Align Auto

Arrangement work of the analyzer will be automatically made every 30 minutes.

SYSTEM >> Align Auto

■ Show System

This shows the model number, serial number, firmware version, the version of each board within the device, and the state of the set-up of an option of the analyzer.

SYSTEM >> Show System

■ Diagnostics

▪ Front Panel Test

This enables you to check the function of keys on each front panel. Whenever you press a key or turn the knob, the number next to it will be increased. To end the test, press ESC.

SYSTEM >> Diagnostics >> Front Panel Test

▪ Screen Test Black Pixel

This displays the pixels of the LCD display screen as all black.

SYSTEM >> Diagnostics >> Screen Test Black Pixel

▪ Screen Test White Pixel

This displays the pixels of the LCD display screen as all white.

SYSTEM >> Diagnostics >> Screen Test White Pixel

■ **Program Update**

The LPT-6000 offers convenient ways to update firmware. Copy the firmware update file downloaded from the corporate website onto a USB flash memory. Insert the USB flash memory into the front USB port, and press the appropriate menu key. You will see a file list. Press the update menu key while placing the file selection bar on the update file. A message reading “Program update success. Reboot LPT-6000.” should appear in a status window on the lowest part of display LCD, when the update was successful. Turn off the power to the analyzer and turn it on again to apply the updated file.

SYSTEM >> Program Update

5-21. Trig

This selects the trigger mode of the analyzer.

■ **Free Run**

When sweep is over, another sweep will immediately start.

TRIG >> Free Run

■ **Video**

This is synchronized with an ascending angle of detection wave bigger than trigger level, thus it will start a sweep.

TRIG >> Video

■ **Line**

This is synchronized with AC power frequency, so it will start a sweep. Line trigger is conveniently used when observing waves related to power.

TRIG >> Line

■ **External Pos Neg**

This is synchronized with an external trigger source, thus, it will start a sweep. The sweep starts from the ascending/descending angle of the signal wave form inputted from the EXT TRIG input connector on the back panel. To start the trigger, a TTL input signal is required. TRIG >> External

■ Trig Delay On Off

You can set the delay of the time that the analyzer is waiting, or turn it on or off before starting a sweep after receiving the external trigger signal. This function can be used only when there is an external trigger.

TRIG >> Trig Delay

5-22. Trace

Allows the user to manipulate and save trace information displayed on the LCD screen. The spectrum analyzer renews the trace information after every sweep.

■ Trace 1 2 3

To select a trace, press the soft key Trace 1 2 3 until the number of the desired trace is underlined.

TRACE >> Trace

■ Clear Write

This deletes data previously saved in the trace memory. It saves amplitude data newly acquired after sweeping, and indicates the amplitude data on the LCD display screen. This function is applied to trace 1 when inputting power.

TRACE >> Clear Write

■ Max Hold

The Max Hold function displays and continuously updates the trace to display the highest peak amplitude of signal level.

TRACE >> Max Hold

■ Min Hold

The Min Hold function displays and continuously updates the trace to display the lowest amplitude of signal level.

TRACE >> Min Hold

■ **View**

The View function freezes the trace and displays trace information. The trace information is not updated even after a sweep. To return to a continuous trace, press the "Clear Write" key.

TRACE >> View

■ **Blank**

This saves amplitude data on the selected trace, and deletes it on the display. The trace memory selected will not be renewed even after sweep. This function will be applied to trace 2 and 4 when inputting AC power.

TRACE >> Blank

Chapter 6

Options

In this chapter we will review the LPT-6000 Spectrum Analyzer's additional options

Chapter 6. Options

6-1. Specifications

- ▶ **Opt-1** : GPIB interface
IEEE 488 Bus

- ▶ **Opt-2** : ETHERNET interface ; for Internet Remote Control

- ▶ **Opt-3** : SOFT CARRYING CASE

- ▶ **Opt-4** : General KIT SET
SMA-N adapter × 2
10 dB attenuator × 1, 20dB attenuator × 1
RF cable (SMA-SMA, RD316, 300 mm) × 2
Kit box × 1

- ▶ **Opt-5** : CATV KIT SET
N-BNC adapter × 2
50Ω ~ 75Ω adapter × 2
RF cable (N-N, RD223, 1000 mm) × 2
Kit box × 1

- ▶ **Opt-6** : RETURN LOSS BRIDGE KIT SET
Termination 50Ω × 1
Cap with chain × 1
RF cable (N-N, RD223, 1000 mm) × 2
Kit box × 1